

USER MANUAL

WARRANTY



HYDRAULIC SLURRY PLOUGH SCRAPER

INDEX: MRSH

Bytów 2020
TRANSLATION OF THE ORIGINAL INSTRUCTION
Revision 01



NOTE!

Before using the machine, please read thoroughly this User Manual and observe the safety instructions contained herein.

The User Manual is an integral part of the machine!

Keep the User Manual in a safe place, where it should be accessible to the machine operator during an entire lifespan of the machine.

In the event of its loss or damage, the user must acquire a new copy from the machine dealer or manufacturer.

In the event the machine is sold or made available to another user, the User Manual must be attached with the declaration of conformity for the machine.

The Manufacturer reserves its copyrights to the User Manual.

Copying, processing of the User Manual and its parts without the manufacturer's permission is strictly prohibited.

The information included in the Manual is valid as of the date of its issue. As a result of product improvements, some data and illustrations may not correspond to the actual state of the machine delivered to the customer. The manufacturer reserves the right to make design changes to improve the product without amending this publication. If you do not fully understand the information contained in this manual, please contact the manufacturer or your local dealer.

Table of Contents

1. Introduction
2. Rules of safe operation
 - 2.1. User safety
 - 2.2. Safety signs on the bucket
 - 2.3. Hazards during operation
3. Intended use
4. Description of the device
 - 4.1. Equipment and accessories
 - 4.1.1. Basic
 - 4.1.2. Optional
 - 4.2. Technical specification
 - 4.3. Forces acting on the bucket
 - 4.4. Assessment of the stability of the tractor with the machine connected
5. Machine operation
 - 5.1. Attaching the bucket
 - 5.2. Hydraulic control system
6. Operation and maintenance
 - 6.1. Scrapping, environment
7. Spare parts catalogue
8. Warranty
9. Declaration of conformity

1. Introduction

Before the first use of the plough, you must thoroughly read and understand this User Manual, and follow all the instructions contained herein.



NOTE!

Before use, read the User Manual.

This manual contains a description of hazards that can occur in case of non-compliance with safety rules during operation and maintenance of the plough. It specifies precautionary measures to be taken to minimise or avoid risks.

This manual also contains the rules for proper use of the plough and explains the required maintenance procedures.

If the information contained in the User Manual is unclear, please contact the manufacturer.



CAUTION!

This symbol warns of a hazard.

The warning symbol indicates an important hazard information provided in the User Manual. Please read the information, follow the instructions and exercise particular caution.

2. Rules of safe operation

2.1 User safety

The plough can only be used by adults, who have learnt its operation and read this User Manual, and are properly qualified. The ploughs should be operated with all necessary precautions, in particular:

- Apart from this User Manual, observe also general rules of health and safety at work.
- Observe warning symbols placed on the machine.
- Never allow the vehicle towing the plough to be operated by a person other than its operator, and in any case do not allow other people to remain in the vehicle or by the machine while in operation.
- The plough may be operated by a person with the proper authorisation to drive the vehicle to which it is attached (aggregated), in accordance with the manufacturer's instructions.
- The operating position of the operator, while working with the snow plough, is the cabin of the vehicle to which the plough is attached.
- Please note, that there are many elements of the plough that may cause an injury (sharp edges, protruding parts, etc.). During the use of the equipment, exercise particular caution when moving close to the above-mentioned critical spots, and it is obligatory to use the following personal protection equipment:
 - protective clothing,
 - protective gloves,
 - protective footwear,
- It is forbidden to carry persons or objects on the plough.
- Moving, pushing **solid objects** is prohibited. In this respect, it is essential to follow the manufacturer's instructions.
- Persons who have not read the User Manual are not allowed to operate the plough.
- When working with manure, it is necessary to wear protective clothing appropriate to the material being pushed, in particular: rubber boots, gloves, coat, cap, and respirator.
- The personnel operating the plough outside of the workplace should be provided with a first-aid kit containing measures for first aid, along with instructions regarding their use.
- Immediately seek medical advice in case of poisoning or infection.
- When driving a vehicle with attached, but not working plough, ensure the safe transportation height of ~ 0.3m.
- Take special care when driving on public roads, and comply with the applicable road traffic regulations.
- Adjust the transport speed to the surface condition.

- In order to maintain manoeuvrability, select the plough allowing for the type of the vehicle, in line with the recommendations of the manufacturers – both of the vehicle and the plough – as well as the linkage system of the vehicle. The attachment rules from the plough manufacturer are described in section 5.1. Snow plough assembly - of these instructions.
- Axle load on any of the axles of the vehicle with the plough installed must not be less than 20% of its weight.
- Do not leave the vehicle with the mounted plough on slopes or other inclines without securing the vehicle against accidental rolling away. The plough should be lowered to the ground. Place wedges under the wheels.
- The plough must be adjusted to working height, during its attachment to the vehicle. The position adjustment of the equipment during its operation is possible from the vehicle cab without the need to leave the cab by the operator.
- After the first hour of operation, check all disjoint connections like bolt connections.
- The plough should be stored on a flat, level, paved surface, out of the reach of bystanders and animals. Use a parking jack for stable plough positioning.
- Exercise caution during the mounting and dismounting of the plough, pay particular attention to the structural elements that connect the bucket to the vehicle.
- Before working with the plough, check the condition of the plough and the vehicle it is coupled to. The assembly, the vehicle and the plough must be in good technical condition. Any worn or damaged parts must be replaced immediately.
- The plough must have all guards covering movable parts in place (if the manufacturer has equipped the unit with such guards). The guards must be complete and fully operational.
- Before beginning to work with the plough, familiarise yourself with the way it operates, occupational safety rules and recommendations for maintenance and adjustment procedures, by reading this manual.
- Before starting work, familiarise yourself with the plough controls and its general operation.
- The weight of the plough mounted on the vehicle may affect the manoeuvrability. In such a situation exercise particular caution.
- The User Manual must be kept near the plough. Before lending the plough, make sure the equipment is operational and has its User Manual attached.
- Prior to commencing work, prepare the plough in line with the recommendations specified in item: 5. Machine operation, Plough assembly.
- Do not attach any additional transport means to the plough.
- During the start-up, check the plough for functionality and make initial adjustment without load.











- Mount the protective devices for the plough pins only using typical cotter pin as protection. Do not use other securing methods.
- Due to wear and tear of the materials please follow the recommendations described in Chapter 6. Operation and maintenance.
- Check the hydraulic and electrical systems of the plough prior to commencing any work. Actuators, hydraulic lines and connections must be tight. Any worn or damaged parts must be replaced immediately.
- During the operation of the unit, the hydraulic lines are under high pressure. The hydraulic lines must be depressurised prior to connecting and disconnecting the hydraulic system with the system of the vehicle.
- When commissioning and transporting the plough, inspect its technical condition to check for damage.
- It is forbidden to stand under the raised snow plough, as it may result in being crushed by the structural elements.
- When adjusting, keep your fingers and limbs away from the structural parts of the plough.
- When using the plough, the operator must make sure nobody gets close to or stays near it.
- Do not stay between the vehicle and the plough when the vehicle's engine is running.
- Working on slopes exceeding 8% is not allowed.
- Exercise particular caution when working on slopes.
- Exercise particular caution when making turns or u-turns with the plough mounted on the vehicle, both during transport as well as while making u-turns, particularly with people, animals or objects near the machine.
- Never leave the vehicle unattended when the engine is running. Before leaving the driver's seat, lower the plough to the ground, switch off the vehicle's engine, remove the ignition key, and apply the handbrake.
- Avoid wearing unbuttoned, hanging parts of work clothes during the operation, assembly, disassembly or adjustment. Keep such clothing elements away from components that can catch them.
- Do not dismount the plough from the vehicle until the engine of the vehicle has stopped and the key has been taken out of the ignition.
- After work it is recommended to clean and wash the plough in the wash fitted with a sewage treatment plant or a settler to neutralise the resulting waste water.
- The snow plough should be kept and stored on a flat, hardened surface, under a protective canopy in places protected from unauthorised access of persons and animals, thus eliminating the risk of accidental injuries.
- In case of failure, immediately turn off the drive transmitted from the vehicle.

- The plough must not be operated by persons under the influence of alcohol or other intoxicants.
- Any maintenance operations, which require working close to the plough, must be carried out with the plough lowered to the ground and with the vehicle engine stopped.
- The snow plough can only be controlled from the operator's cab of the vehicle to which the plough is connected.



Failure to follow the above rules may be dangerous for the operator and bystanders and can cause damage to the plough. The user is responsible for damage resulting from non-compliance with the above rules.

2.2. Safety signs on the machine and their meaning

 <p>1.0 - Prior to using the machine, read the User Manual</p>	<p>C.2.26</p>  <p>1.1 - Switch off the engine and remove the ignition key before any servicing or maintenance procedures</p>	<p>A.6.2 + B.2.6</p>  <p>1.2.1 – Keep a safe distance from the machine. Hazard of finger/toe crushing Force applied from the top.</p>	
<p>C.2.7</p>  <p>1.5 - Do not stand near the lift strands when controlling the lift</p>	<p>C.2.44</p>  <p>1.8 – Avoid exposure to liquids flowing under pressure. Read the User Manual and learn about the maintenance works</p>	 <p>3.1 – Warning message about pressure in the hydraulic system</p>	
<p>2.3 – Wear a protective suit</p> 	<p>2.3 – Wear safety shoes</p> 	<p>2.4 – Use safety gloves</p> 	<p>2.3 – Use protection goggles</p> 

2.3. Hazards during snow plough operation

<i>Item</i>	<i>Risk</i>	<i>Hazard source (cause)</i>	<i>Risk preventive measures</i>
1	Overloading the locomotor system (physical load)	Working in a standing position, inclined-forced position, walking, moving objects	Read and understand the User Manual; do workplace training in carrying weights standards for the manual handling, correct methods of lifting and carrying loads, getting other persons' help, and the use of handling devices such as jacks and winches.
2	Fall on the same level (tripping, slipping, etc.)	Uneven terrain, messy environment – objects lying and standing around, cables lying on communication roads, slippery surfaces	Suitable footwear, levelled terrain, paying attention, maintaining order, reading the User Manual
3	Bumping into stationary, protruding parts of the machine	The machine and its surroundings	Proper positioning of a machine, safe space to move around, proper organisation of work, paying attention, reading the Instructions Manual
4	Being struck by moving objects	Discarded shredded and raked plants, random turf parts, stones	Maintain caution, mark the danger zone, walking in the immediate surrounding of the working machine is not allowed, use personal protective equipment (helmet, safety glasses), read the User Manual.
5	Sharp, dangerous edges	Protruding parts of the machine structure, use of hand tools	Personal protective equipment – safety gloves, buttoned up work clothes, exercising special attention
6	Movable machine parts	Movable machine elements, moving piston rods of hydraulic cylinders, no guards on movable parts	Prohibition of moving and making adjustments on the running machine, exercising caution, using shields of moving parts, reading the User Manual
7	Weight of the suspended stationary machine	Improper mounting or coupling, wrong position of the machine, improper operation, leaving the suspended machine on a tractor	Exercising special attention, use of personal protective equipment - safety footwear, safety gloves, secure position of the machine, help of others, use of lifting jacks and hoists, reading the Instructions Manual
8	Micro climate - variable weather conditions	Work carried out in different weather conditions	Suitable working clothes, beverages, creams with sun screens, proper rest, reading the Instruction Manual
9	Noise	Excessive rotational speed of the machine, damaged, loose, vibrating parts	Operation of the machine in good technical condition, inspections on a regular basis, proper rotational speed, reading the Instruction Manual

3. Intended use

Slurry plough used to remove manure, slurry, feed, grain or snow from level surfaces.

Complying with the requirements for the use of the machine, its operation and repairs strictly according to the manufacturer's guidelines is the condition for the use of machine as intended. The plough must be operated, maintained and repaired exclusively by persons familiar with its specific characteristics and acquainted with the rules of conduct in terms of health and safety.

The manufacturer has a wide range of slurry and manure ploughs for sale. It also provides specialist advice on choosing the right equipment according to the user needs.



In case of any doubts regarding the intended used of the equipment, please contact the manufacturer of the snow plough. Selecting the right equipment and knowing its intended use makes its operation safer.

4. Description of the device

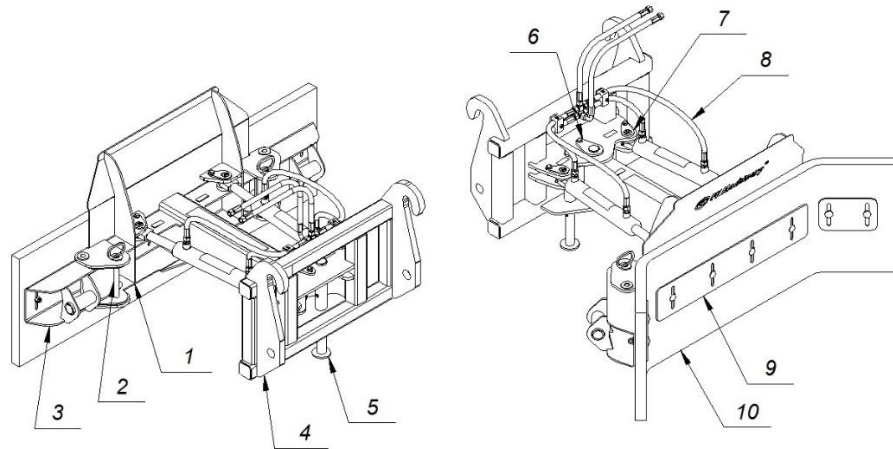

Fig. 2 MRSH hydraulic slurry plough scraper.

The Fig.2 MRSH plough is constructed from two main structural components that are articulated together.

The first component, the **frame (1)**, is made of steel plates and a thick-walled profile, welded together to form a rigid body.

The second element, a **frame with a mount (4)**, is made of thick-walled steel profiles and steel plates welded together.

The two parts can move relative to each other thanks to an articulated connection via a pin (6) and a hydraulic control system (8) which, when connected to the vehicle, is controlled from the operator's cab.

Both ends of the blade, can be turned through an angle of 45° Fig. 3, by means of pivoting supports (3), which are locked with pins (2). Holes in the tubes can be used for this, into which a steel rod must be inserted. A parking jack (5) is embedded in the frame, which has to be lifted up for plough operation and secured with a pin.

Hydraulically controlled MRSH plough can be used with vehicles equipped with a power hydraulics system typically used for front attachment in vehicles.

The design allows the plough angle to be adjusted to the driving axis in 3 positions from +50° to -50° Fig. 3

The ploughs produced are classified as mid-range ploughs due to their design and specification.

Basic linkage systems used in our ploughs include the following:

- TUZ (three-point linkage) I, TUZ II, TUZ III
- EURO linkage
- SMS linkage

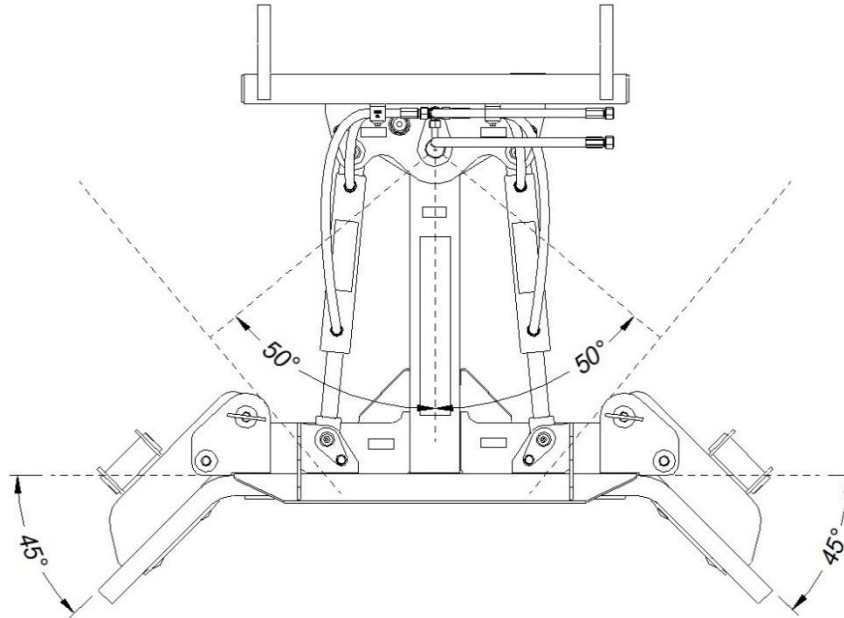

Fig. 3 Plough settings relative to the travel axis.

4.1. Equipment and accessories

4.1.1. Basic

The basic equipment of a snow U-plough includes:

- Parking jack
- The hydraulic control system with power hydraulics lines
- User Manual
- Warranty Certificate



The plough is **not** supplied with a portable warning light or a triangular slow vehicle warning sign.

4.1.2. Optional

4.2. Technical specification

Table No. 1 HYDRAULIC PLOUGH SCRAPER - TECHNICAL DATA

Item	Specification	UOM	Parameter						
1	Plough type	–	MRSH						
2	Version (Working width)	–	150	170	200	220	240	260	300
3	Machine class	Hitched, medium class							
4	Overall dimensions								
5	Length	[mm]	850						
6	Height	[mm]	650						
7	Working width for -50°/+50° position - straight blade	[mm]	1000	1125	1320	1450	1570	1700	1960
8	Working width for -50°/+50° position - blade ends bent	[mm]	870	1000	1190	1320	1450	1540	1840
9	Plough weight	[kg]	230	242	265	273	280	295	315
10	Setting of the working position	[°]	From -50° to +50° - infinitely variable						
11	Drive and steering	–	Hydraulic control system						
12	Pressure of the hydraulic system	[MPa]	16 ÷ 20						
13	Transport clearance	[mm]	300						
14	Working speed	[km/h]	4 ÷ 8						
15	Vehicle power requirement	[HP]	30+						
16	Number of operators	[pcs.]	1						
17	Vehicle attachment type	[-]	Acc. to instruction						

4.3. Forces acting on the plough

The extremes occurring with the operation of the plough are comparable to a collision. It is important to be aware of the forces involved when operating a heavy vehicle with a plough. Reading the User Manual will ensure safe use and reduce the consequences of operating errors - reducing risks.



The high forces acting on the vehicle-plough system require operators to be highly skilled and speak to the awareness of the risks involved when working with a plough.

It is very important to select the speed of the vehicle in a properly safe manner so that the work being carried out does not endanger the environment or the vehicle operator.

5. Machine operation

5.1. Plough assembly



Make sure that the connecting parts of both the vehicle and the plough are suitably adjusted to each other. In case of any doubts, contact the manufacturer of the vehicle or the plough.

As two systems of the plough must be connected to the vehicle, the mounting sequence should be as follows:

I. Connecting the mechanical systems of the vehicle and the plough.

Depending on the three-point hitch suspension system type, make sure the original safety elements are present. Each time the machine is mounted on the vehicle, check the connecting elements, i.e. pins and plugs, for wear.

II. Installing power hydraulic system

A plough with a hydraulic control system is equipped with hoses that must be connected to the vehicle's supply system connections. Make sure the lines are routed correctly and the hydraulic connections are clean.

To dismount the plough, follow the above instructions in a reverse order, exercise particular caution when disconnecting the mechanical system between the plough and the vehicle.



5.2. Hydraulic control system

The MRSH plough is controlled from the vehicle operator's cab. The plough is equipped with terminals of the power hydraulics system, which, once connected with the hydraulic system of the vehicle, enable seamless control of the plough.

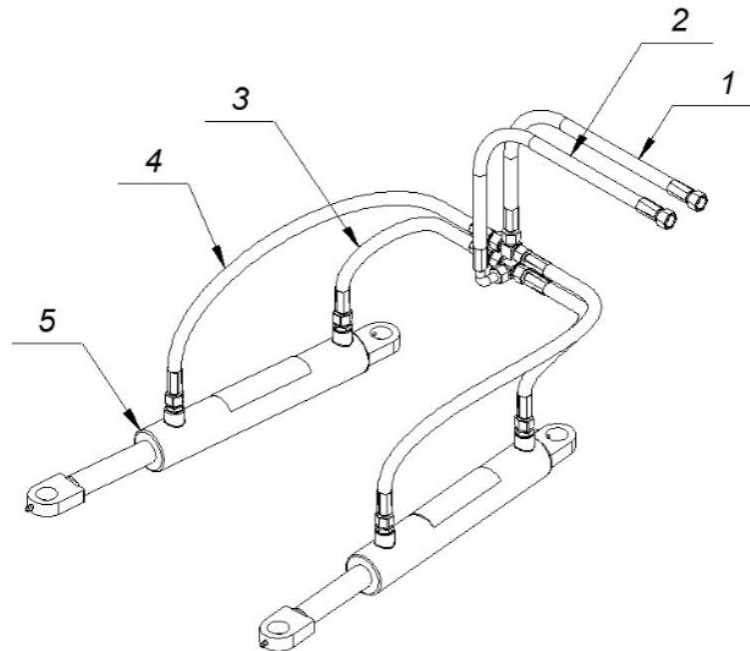

Fig. 4 Hydraulic system of the MRSH plough

- (1) - Przewód hydrauliczny;
- (2) - Przewód hydrauliczny;
- (3) - Przewód hydrauliczny krótki;
- (4) - przewód hydrauliczny długi;
- (5) - Siłowniki hydrauliczne;

6. Operation and maintenance



The operator of the vehicle onto which the plough has been mounted may carry out all actions related to its operation provided they have proper authorisation to operate this vehicle. Read the user manual of the plough prior to operating the equipment.

6.1 Maintenance after work

Each time the work has been completed, clean the plough and place it on a flat and hard ground. Next, check the connections between particular parts and assemblies. Replace damaged or worn elements with new or remanufactured ones. Check all screw connections and tighten if necessary. All safety signs placed on the plough should be kept clean.

6.2 Lubrication of flexible joints

Basic maintenance includes greasing flexible joints of the plough. Once in a season, apply ŁT-42 grease onto all movable parts of the plough. Remove soiling and old grease before applying new grease.

Any parts showing wear must be replaced with new ones.

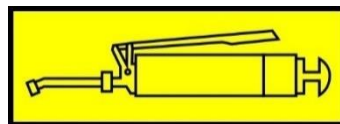

Symbol for lubrication points marked on the machine.

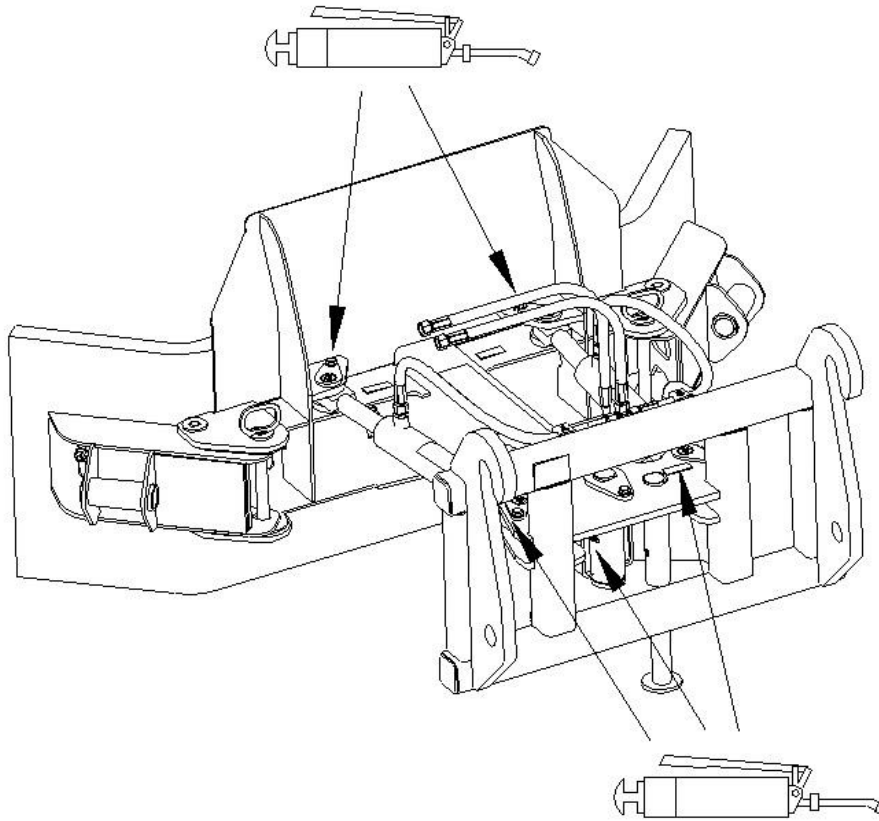

Fig. 5 Lubrication points on the MRSH plough

6.3 Out-of-season maintenance

Includes all actions specified in section “Maintenance after work”. Additionally, the plough should be kept under a roof, on a flat and hard ground. Make sure the paint coat is intact. If there are any defects in the coat, clean the spot and apply a new protective coating.



In the case of leaks from the hydraulic system, the damaged parts and components must be replaced to avoid contamination of the environment. **Hydraulic lines, regardless of their external condition, must be replaced after 5 years.**

6.4 Scrapping, environment

Hand over the machine for disposal if it is worn to the extent which prevents its further use. This also applies to regular repairs and replacement of damaged parts. Clean the machine thoroughly before scrapping. Drain oils from the machine and have the machine decommissioned. Next, disassemble the machine by segregating its parts based on the applied materials. Segregated parts should be transported to a scrap yard or disposed of.

The machine is 100% environmentally friendly. 97% of the materials used in the production process are recyclable. Worn machine parts must be disposed of in line with the local environment protection regulations. Prevent oil leakage throughout the period of use of the machine, as oil may pollute the environment.

7. Spare parts catalogue

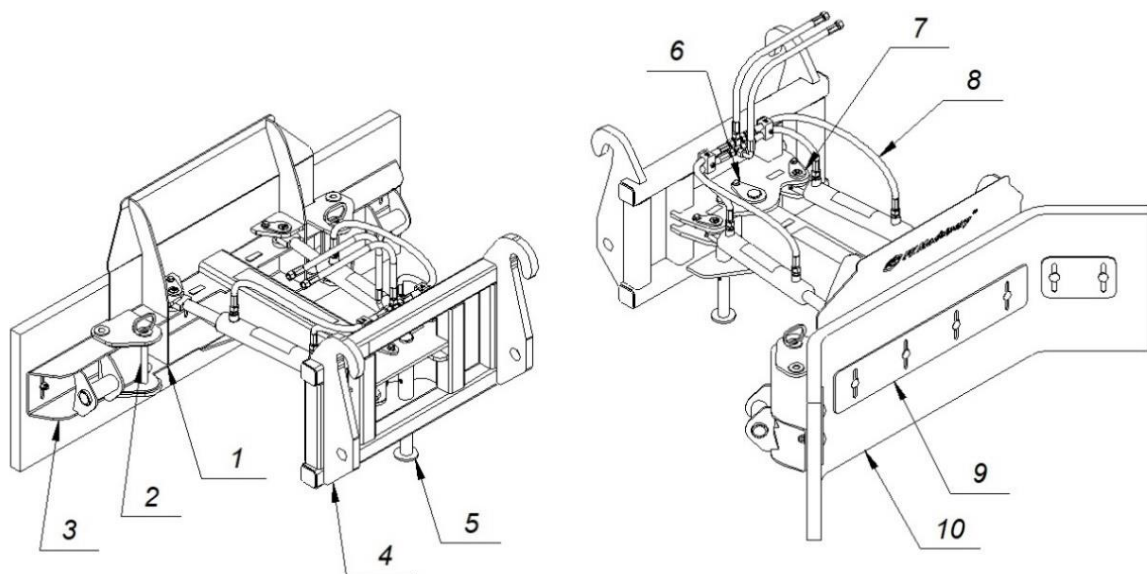

Fig. 7 MRSB hydraulic slurry plough scraper.

- (1) - Body; (2) - Locking pin; (3) - End arm; (4) - Frame with a mount;
- (5) - Parking jack; (6) - Pivot pin; (7) - Cylinder pins;
- (8) - Hydraulic system; (9) - Pressure plates; (10) - Rubber blade;



Spare parts should be ordered at points of sale of the machines or from the manufacturer. Use only the original spare parts provided by the manufacturer, to guarantee safe and reliable operation of the machine. The use of not original spare parts or parts, which have been repaired, will void the warranty.

8. Warranty

WARRANTY CERTIFICATE

Serial No.	Type
Year of manufacture	Quality Control Department

Under the warranty, the manufacturer undertakes to repair, free of charge, any physical defects revealed during the warranty period, i.e. 12 months from the date of sale.

The manufacturer will be exempt from liability under the warranty in case of:

- Mechanical damage of the machine, which occurred after it was delivered to the user;
- Improper operation, maintenance or storage of the machine, in particular, contrary to the User Manual;
- Repairs carried out by unauthorised persons without the consent of the manufacturer;
- Introducing design changes without consulting the manufacturer;

The warranty certificate is valid provided it has the vendor's signature and the date of sale certified with the company stamp. It must not contain deletions and amendments by unauthorised persons.

A duplicate of the warranty certificate may be issued upon a written request after presentation by the user of the proof of purchase.

In the case of an unjustified service call to warranty repair, the related costs will be borne by the user.

The user will file complaints within 14 days from the date of damage/defect directly to the vendor.

The manufacturer will carry out warranty repairs within 14 days from the date of the complaint. The warranty will be extended by the repair time counted from the date of the complaint until to the date of completion of the service if the defect prevents the use of the machine.

The warranty shall not cover the hydraulic lines of the machine.

Date of sale: _____
(Day, month, year)

(signature and stamp of the point of sale)

WARRANTY REPAIRS RECORDS

Filled in by the manufacturer

Date of complaint claim: _____

The scope of repair and parts used: _____

Date the fault was rectified:

Warranty extended until: _____

(signature and stamp of the service)

Date of complaint claim: _____

The scope of repair and parts used: _____

Date the fault was rectified:

Warranty extended until: _____

(signature and stamp of the service)

Date of complaint claim: _____

The scope of repair and parts used: _____

Date the fault was rectified:

Warranty extended until: _____

(signature and stamp of the service)

Date of complaint claim: _____

The scope of repair and parts used: _____

Date the fault was rectified:

Warranty extended until: _____

(signature and stamp of the service)

CE Declaration of Conformity

DECLARATION OF CONFORMITY

No.: /.....

1. Manufacturer of the product:

Kołaszewski
 ul. Lęborska 22
 77-100 Bytów

2. Product name:

Hydraulic slurry scraper Type; MRSH

Year of manufacture: Serial No.:

3. Product classification:

PKWiU (Polish Classification of Products and Services) 35.50.10-00.96
Vehicle assemblies and parts excluding the drive, other

4. Intended use and scope of application of the product:

Slurry plough, used to remove manure, slurry, feed, grain or snow from level surfaces.

5. Reference documents:

EU laws		Polish laws	
Directive No.	Title	Document name	No.
2006/42/EC	Machinery Directive	Ordinance of the Minister of Economy of 21 October 2006 regarding essential requirements for machines	Journal of Laws No. 199/1228
Standard No.	Title		
PN-EN ISO 12100-1:2005	Machines. Safety. Basic concepts, general design principles. Part 1: Basic terminology, methodology.		
PN-EN ISO 12100:2011	Safety of machinery – General principles for design – Risk assessment and risk reduction		
PN-EN 14121-1:2008	Safety of machinery – Risk assessment – Part 1: Principles		
PN-ISO 730-1:1996	Agricultural Wheeled Tractors – Rear-mounted three-point hitch suspension system – Categories 1, 2, 3 and 4		
PN-EN ISO 4254-1:2009	Agricultural machinery – Safety – Part 1: General requirements		
PN-EN ISO 13857:2010	Safety of machinery – Safety distances to prevent hazard zones being reached by upper and lower limbs		
PN-ISO 11684:1998	Tractors, agricultural and forest machinery, powered lawn and garden equipment. Safety signs and hazard pictorials. General rules.		
PN-ISO 3600:1998	Tractors, agricultural and forest machinery, powered lawn and garden equipment – Instruction manual – Content and presentation		
PN-M-73022:1973	Hydraulic drives and controls – Hydraulic controls – division and marking		
Procedure P06.01	System procedure P06.01, issued 05/01/2011. Process supervision		

Conformity with the requirements of the directives and standards has been ascertained based on the tests conducted by:

„FITMECH” Fundacja Inżynierów i Techników Mechaników Polskich w Słupsku.

The tests were carried out by: mgr inż. Zbigniew Myszka – expert of the Association of Polish Mechanical Engineers & Technicians No. 9763/11

I hereby declare, taking full responsibility, that the product conforms to the reference documents referred to in item 5.

.....
 (place and date of issue)

.....
 (name and signature of the authorised representative of the Manufacturer)